



## FLAREMOUNT™ TECHNOLOGY ASSEMBLY PROCEDURES

### *Instructions for Galtek® SG Manifold Valves using FlareMount™ Sealing Technology*

#### REPAIR PROCEDURE

1. Remove original valve assembly (P1) from manifold block (P2) by loosening the two capscrews (P3), see Figure 1.
2. Place lock washers (P4) onto capscrews and insert capscrews through top holes on new valve assembly.
3. Place new valve assembly on manifold block by aligning the two capscrews with the mating holes on the block.
4. Tighten the two capscrews until both are hand tight.
5. Torque each capscrew to 64 in•oz (.45 N•m). To avoid damaging the manifold block, do not overtighten.
6. Assembly is complete. See testing procedures.

#### TESTING

##### Valve to Manifold Leakage

Apply 80 PSIG (552 kPa) air pressure to the inlet. No leakage between the valve and the manifold should be seen when the manifold is submerged in water.

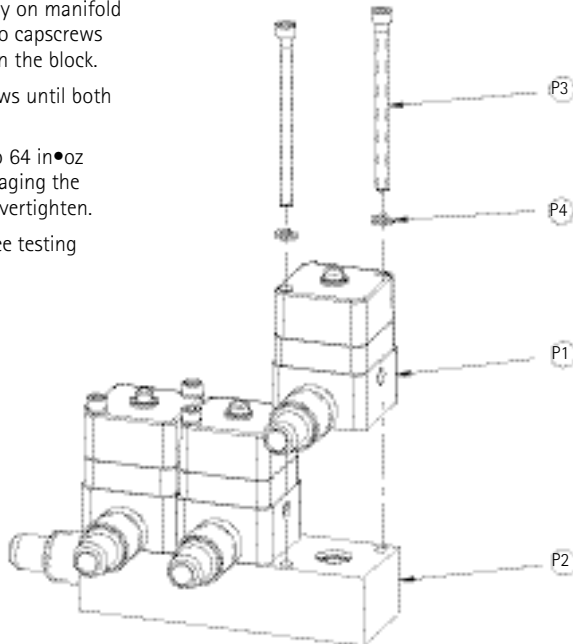

Figure 1

Entegris manufactures a complete line of critical fluid management products including valves, tubing, fittings, fusible piping products, sensing products, chemical containers and sanitary products. For information contact Entegris, Inc.

**WARRANTY** – Entegris warrants each of its new products against defects in materials and workmanship for the following periods of time from shipment: Wafer Management products, Integrated Shipping Systems products, Test, Assembly and Packaging products, Custom products – 90 days; Entegris<sup>™</sup> Cleaning Systems and AutoPod<sup>™</sup> Wafer Carriers – 1 year; Critical Fluid Management products (except as separately identified below) including FluoroPure<sup>®</sup> Chemical Container products – 1 year; Sheeted Chemical Container products and FluoroPure<sup>®</sup> PFA Liners (blistering, cracking or leakage only) – 18 months; FluoroPure<sup>®</sup> o-rings and gasket materials – 90 days. Entegris makes no warranty, express or implied, with respect to any components, products or services provided by any third party. With respect to products specially manufactured to Buyer's specifications, Entegris warrants only that such products have been manufactured, without testing, to Buyer's specifications but makes no other warranty, express or implied. Upon Entegris' confirmation of defects, Entegris agrees, as its **exclusive remedy** to repair or, in its discretion, replace defective product without charge. Entegris is not responsible for product damage resulting from accident, misuse, or lack of reasonable care.

**IMPORTANT: No other warranty, written or verbal, is authorized by Entegris. Entegris is not liable for any special, incidental or consequential damages. Implied warranties of merchantability and fitness for a particular purpose are specifically disclaimed.**

Entegris<sup>™</sup> is a trademark of Entegris, Inc.  
Galtek<sup>®</sup>, FluoroPure<sup>®</sup>, FlareMount<sup>™</sup> and AutoPod<sup>™</sup> are trademarks of Fluoroware, Inc.

---

## ENTEGRIS, INC.

Corporate Headquarters / 3500 Lyman Boulevard / Chaska, Minnesota 55318 USA  
Customer Service Tel. 952-556-4196 / Customer Service Fax 952-556-8022 / [www.entegris.com](http://www.entegris.com)

©2000 Entegris, Inc. Printed in USA P/N 01-006746 (Rev. B 05/00)